



Main

Range of product	Altivar Process ATV900
Product or component type	Variable speed drive
Device application	Industrial application
Device short name	ATV930
Variant	Standard version With braking chopper
Product destination	Synchronous motors Asynchronous motors
Mounting mode	Wall mount
EMC filter	Integrated conforming to EN/IEC 61800-3 category C3 with <= 150 m motor cable maxi
IP degree of protection	IP21 conforming to IEC 61800-5-1
Degree of protection	UL type 1 conforming to UL 508C
Type of cooling	Forced convection
Supply frequency	50...60 Hz (+/- 5 %)
Network number of phases	3 phases
[Us] rated supply voltage	380...480 V (- 15...10 %)
Motor power kW	11 kW (normal duty)
Motor power hp	15 hp (normal duty)
Line current	19.8 A at 380 V (normal duty)
Prospective line Isc	50 kA
Apparent power	14.1 kVA at 480 V (normal duty)
Continuous output current	23.5 A at 4 kHz (normal duty)
Maximum transient current	28.2 A during 60 s (normal duty)
Asynchronous motor control profile	Variable torque standard Optimized torque mode Constant torque standard
Synchronous motor control profile	Permanent magnet motor Synchronous reluctance motor
Speed drive output frequency	0.1...599 Hz

Disclaimer: This documentation is not intended as a substitute for and is not to be used for determining suitability or reliability of these products for specific user applications

Nominal switching frequency	4 kHz
Switching frequency	2...16 kHz adjustable
Safety function	STO (safe torque off) SIL 3
Number of preset speeds	16 preset speeds
Communication port protocol	Modbus TCP Modbus serial Ethernet/IP
Option module	Slot A : communication module for Profibus DP V1

Complementary

Output voltage	\leq power supply voltage
Motor slip compensation	Can be suppressed Adjustable Not available in permanent magnet motor law Automatic whatever the load
Acceleration and deceleration ramps	Linear adjustable separately from 0.01...9999 s
Braking to standstill	By DC injection
Protection type	Motor : thermal protection
Frequency resolution	Display unit : 0.1 Hz
Electrical connection	Control, screw terminal : 0.5...1.5 mm ² (AWG 20...AWG 16)
Connector type	2 RJ45 (on the control block) for Ethernet IP/Modbus TCP
Physical interface	2-wire RS 485 for Modbus serial
Transmission frame	RTU for Modbus serial
Transmission rate	10/100 Mbit/s for Ethernet IP/Modbus TCP
Exchange mode	Half duplex, full duplex, autonegotiation for Ethernet IP/Modbus TCP
Data format	8 bits, configurable odd, even or no parity for Modbus serial
Type of polarization	No impedance for Modbus serial
Method of access	Slave for Modbus TCP
Supply	External supply for digital inputs : 24 V DC (19...30 V) current \leq 1.25 mA (overload and short-circuit protection)
Local signalling	3 mono/dual colour LED for local diagnostic
Width	171 mm
Height	409 mm
Depth	236 mm
Product weight	7.7 kg
Analogue input number	3
Analogue input type	Software-configurable voltage AI1, AI2, AI3 : 0...10 V DC impedance 30 kOhm, resolution 12 bits
Discrete input number	10
Discrete input type	Programmable DI1...DI8 : 24 V DC (\leq 30 V) impedance 3.5 kOhm
Input compatibility	Discrete input DI1...DI8 : level 1 PLC conforming to EN/IEC 61131-2
Analogue output number	2
Discrete output number	2
Discrete output type	Logic output DQ+ : 0...1 kHz (\leq 30 V) DC, 100 mA
Sampling duration	Discrete input DI1...DI8 : 2 ms (+/- 0.5 ms)
Accuracy	Analog input AI1, AI2, AI3 : +/- 0.6 % for a temperature variation 60 °C Analog output AQ1, AQ2 : +/- 1 % for a temperature variation 60 °C
Linearity error	Analog input AI1, AI2, AI3 : +/- 0.15 % of maximum value
Maximum switching current	Relay output R1 on resistive load (cos phi = 1) : 3 A at 250 V AC
Relay output number	3
Relay output type	Configurable relay logic R1 : fault relay NO/NC electrical durability 100000 cycles
Refresh time	Relay output R1, R2, R3 : 5 ms (+/- 0.5 ms)
Minimum switching current	Relay output R1, R2, R3 : 5 mA at 24 V DC
Isolation	Between power and control terminals
Specific application	Process

IP degree of protection	IP21
Motor starter type	Variable speed drive

Environment

Insulation resistance	> 1 mOhm at 500 V DC for 1 minute to earth
Noise level	56 dB conforming to 86/188/EEC
Power dissipation in W	51 W (natural convection) at 380 V switching frequency 4 kHz
Vibration resistance	1.5 mm peak to peak (f = 2...13 Hz) conforming to IEC 60068-2-6
Shock resistance	15 gn during 11 ms conforming to IEC 60068-2-27
Volume of cooling air	103 m3/h
Operating position	Vertical +/- 10 degree
THDI	<= 48 % from 80...100 % of load conforming to IEC 61000-3-12
Electromagnetic compatibility	Electrostatic discharge immunity test level 3 conforming to IEC 61000-4-2
Pollution degree	2 EN/IEC 61800-5-1
Environmental characteristic	Chemical pollution resistance class 3C3 conforming to EN/IEC 60721-3-3
Relative humidity	5...95 % without condensation conforming to IEC 60068-2-3
Ambient air temperature for operation	50...60 °C with derating factor
Ambient air temperature for storage	-40...70 °C
Operating altitude	1000...4800 m with current derating 1 % per 100 m
Standards	UL 508C
Product certifications	CSA REACH UL TÜV
Marking	CE

Offer Sustainability

Sustainable offer status	Green Premium product
RoHS (date code: YYWW)	Compliant - since 1526 - Schneider Electric declaration of conformity Schneider Electric declaration of conformity
REACH	Reference not containing SVHC above the threshold Reference not containing SVHC above the threshold
Product environmental profile	Available Product Environmental Profile
Product end of life instructions	Available End of Life Information

Dimensions

Front, Left and Rear View

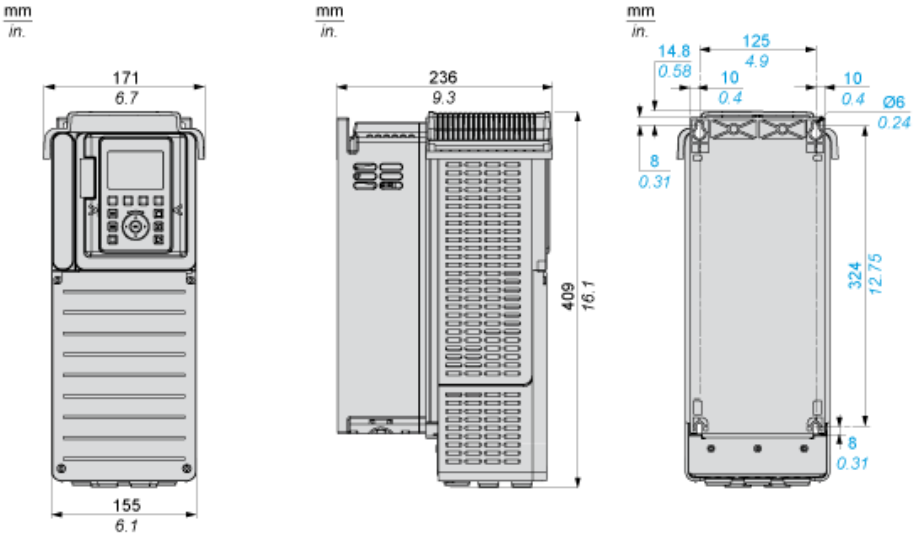

Clearances

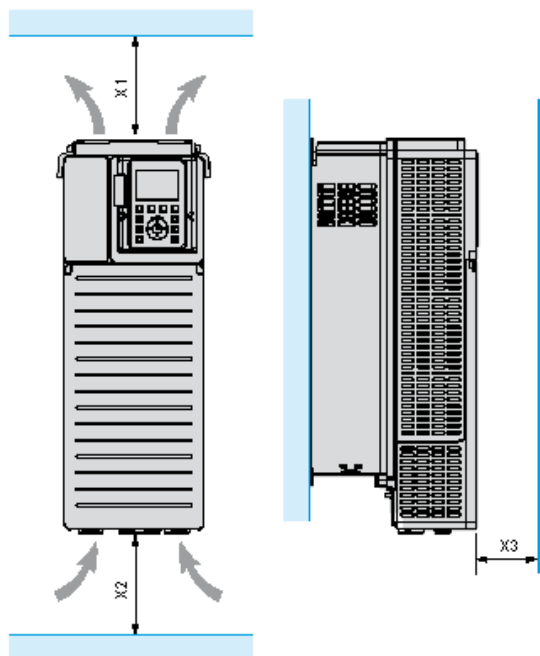

X1	X2	X3
≥ 100 mm (3.94 in.)	≥ 100 mm (3.94 in.)	≥ 10 mm (0.39 in.)

- Mount the device in a vertical position ($\pm 10^\circ$). This is required for cooling the device.
- Do not mount the device close to heat sources.
- Leave sufficient free space so that the air required for cooling purposes can circulate from the bottom to the top of the drive.

Mounting Types

Mounting Type A: Individual IP21

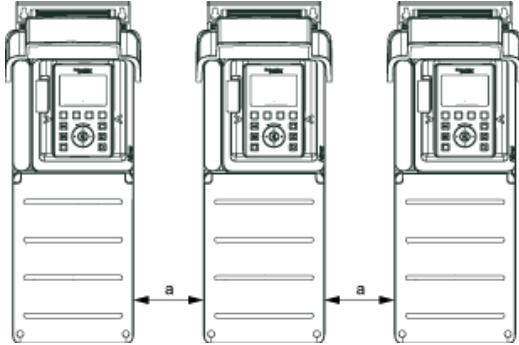

$a \geq 100 \text{ mm (3.94 in.)}$

Mounting Type B: Side by Side IP20

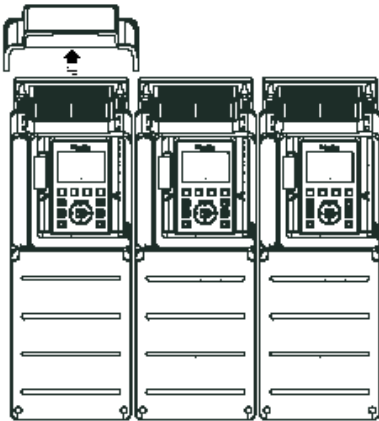

Mounting Type C: Individual IP20

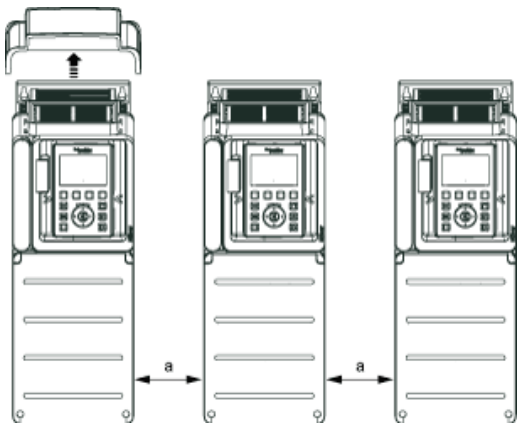

$a \geq 0$

Three-Phase Power Supply with Upstream Breaking via Line Contactor

Connection diagrams conforming to standards EN 954-1 category 1 and IEC/EN 61508 capacity SIL1, stopping category 0 in accordance with standard IEC/EN 60204-1

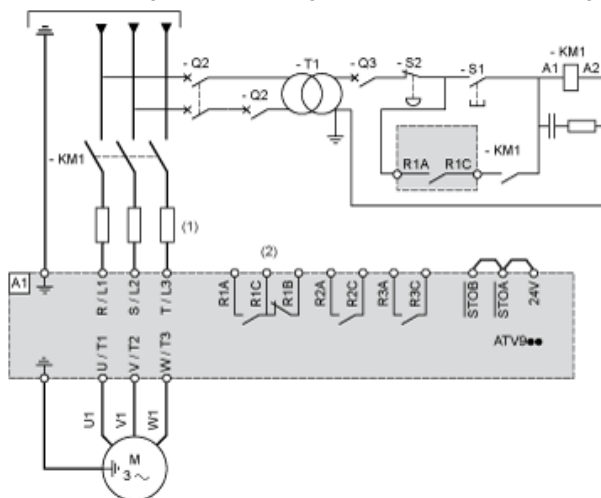

- (1) Line choke if used
- (2) Use relay R1 set to operating state Fault to switch Off the product once an error is detected.
- A1 : Drive
- KM1 : Line Contactor
- Q2, Q3 : Circuit breakers
- S1, S2 : Pushbuttons
- T1 : Transformer for control part

Three-Phase Power Supply with Downstream Breaking via Contactor

Connection diagrams conforming to standards EN 954-1 category 1 and IEC/EN 61508 capacity SIL1, stopping category 0 in accordance with standard IEC/EN 60204-1

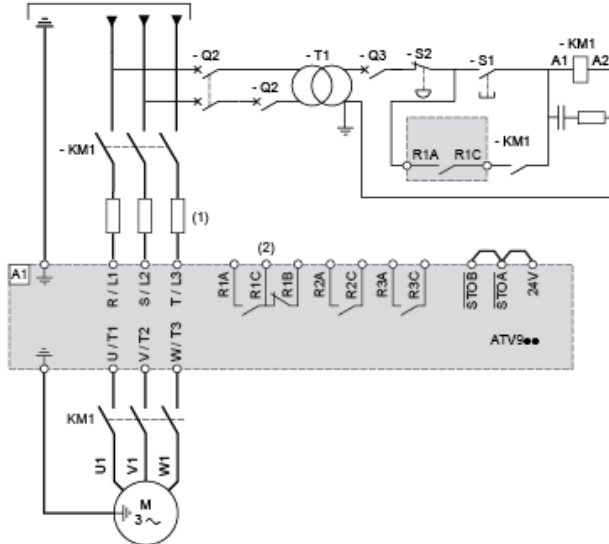

- (1) Line choke if used
 - (2) Use relay R1 set to operating state Fault to switch Off the product once an error is detected.
- A1 : Drive
KM1 : Contactor

Control Block Wiring Diagram

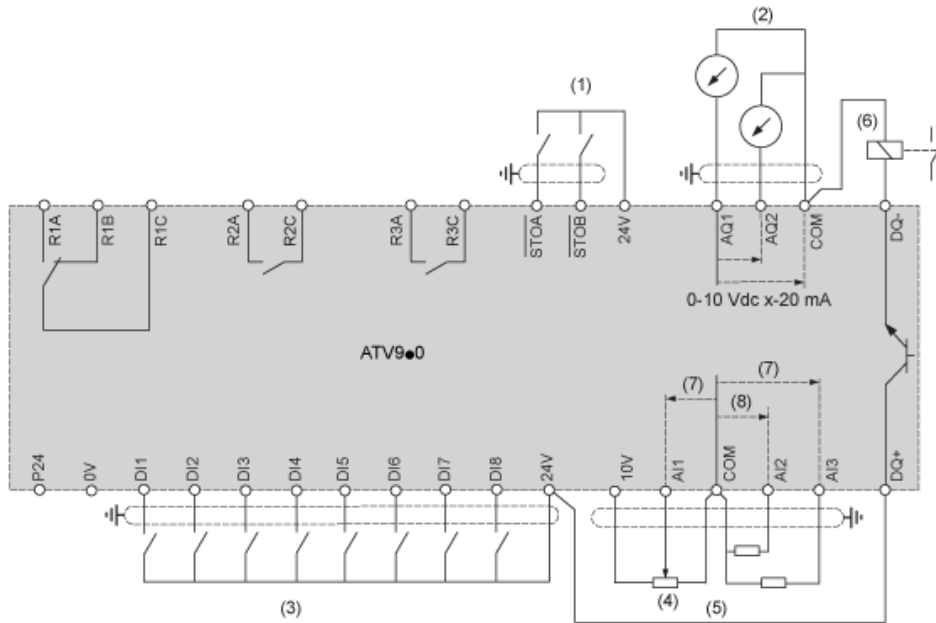

- (1) Safe Torque Off
 - (2) Analog Output
 - (3) Digital Input
 - (4) Reference potentiometer
 - (5) Analog Input
 - (6) Digital Output
 - (7) 0-10 Vdc, x-20 mA
 - (8) 0-10 Vdc, -10 Vdc...+10 Vdc
- R1A, R1B, R1C Relay
R2A, R2C Sequence relay
R3A, R3C Sequence relay

Sensor Connection

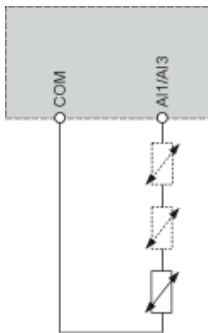

It is possible to connect either 1 or 3 sensors on terminals AI1 or AI3

Sink / Source Switch Configuration

The switch is used to adapt the operation of the logic inputs to the technology of the programmable controller outputs.

- Set the switch to Source (factory setting) if using PLC outputs with PNP transistors.
- Set the switch to Ext if using PLC outputs with NPN transistors.

Switch Set to SRC (Source) Position Using the Output Power Supply for the Digital Inputs

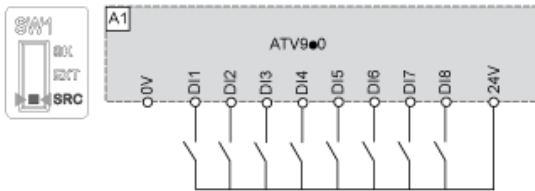

Switch Set to SRC (Source) Position and Use of an External Power Supply for the DIs

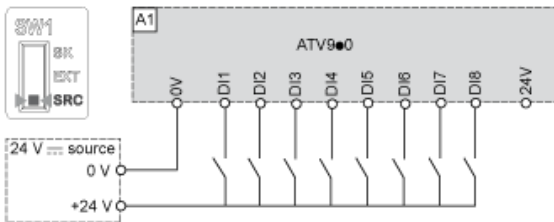

Switch Set to SK (Sink) Position Using the Output Power Supply for the Digital Inputs

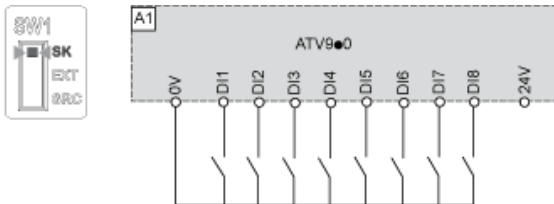

Switch Set to EXT Position Using an External Power Supply for the DIs

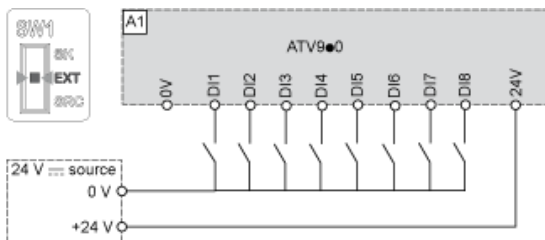

Derating Curves

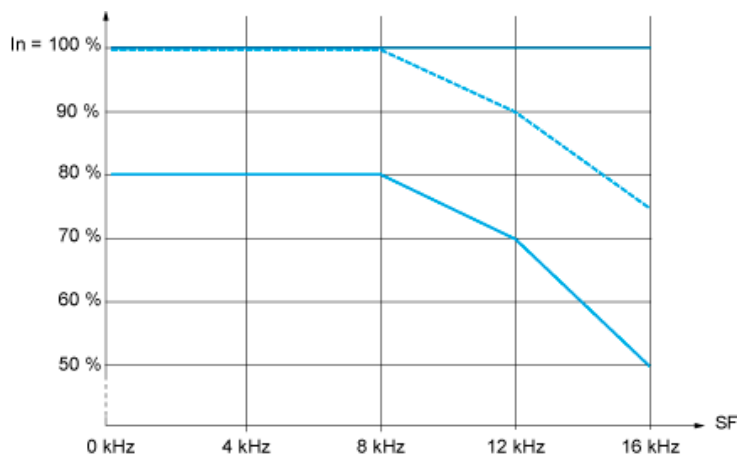

- 40 °C (104 °F) - Mounting type A, B and C
 - - - 50 °C (122 °F) - Mounting type A, B and C
 - 60 °C (140 °F) - Mounting type B and C
- In : Nominal Drive Current
SF : Switching Frequency